



The Internet Journal of Health 2004 : Volume 3 Number 2

Intensive Care Unit

Mohammad Said Maani Takrouri M.B. Ch.B. FFARCS (I)

Department of Anesthesia

College Of Medicine

King Saud University 

Citation: M. S. Takrouri : Intensive Care Unit . *The Internet Journal of Health*. 2004
Volume 3 Number 2

Abstract

The development of intensive care units made the care for more seriously sick patients possible. It allowed utilizing more technically oriented tools to monitor and get information instantly about any changes of the patient's physiological parameters and developed new strategies to save life. On the other hand it raised ethical and professional issues related to some patients who had untreatable medical conditions or those who sustained unsalvageable damage to their vital organs. This article touches on the modern ethical issues raised by development of extending biological life technology like the issues of brain death, the vegetative states and the issue of ceasing resuscitation and further management of terminal illnesses on the light of patient autonomy and right to live. The audience of this article is the general public, students of paramedical and nursing specialties.

Introduction

Doctors in the critical care area can no more offer help to their patients single-handed. The patient who is affected by life threatening conditions like acute respiratory failure, cardiac failure or deep coma etc. needs the undivided attention of somebody who should take over his respiration, control his intake of fluid and watching him minute by minute, day by day, and even weeks. One nurse or one doctor or one team of doctors cannot do this. It needs what we call today an intensive care set up. There we have 'Human Physiological Laboratory'. There, all these goals are met to the advantage of the patients. The purpose of this article is to give basic account on the subject.

Historical Background

The idea of intensive care stems back to the era when better understanding of the human physiology and the process of death occurred. Understanding the function of oxygenation and that life is an oxidation process led to put emphasis on the respiratory support and oxygen inhalation. Lavoisier (1743-1794) stated "*Respiration is a process of combustion, in truth very slow, but otherwise exactly like that of charcoal.*" The reason may be different but many cultures used insufflations of respiratory system with air as effort of resuscitation. In the medical distant history there are many stories of resuscitation of the apparently dead. Remarkably, there is the story of Saleh Ibn Bouhlah, ¹ who resuscitated the cousin of Al-Rashid (ca. 763 - 809) was the 5th and most famous Abbasid Caliph from 786 until 809. using dust of plant Kundus and a Bellows (**Figure. 1**).

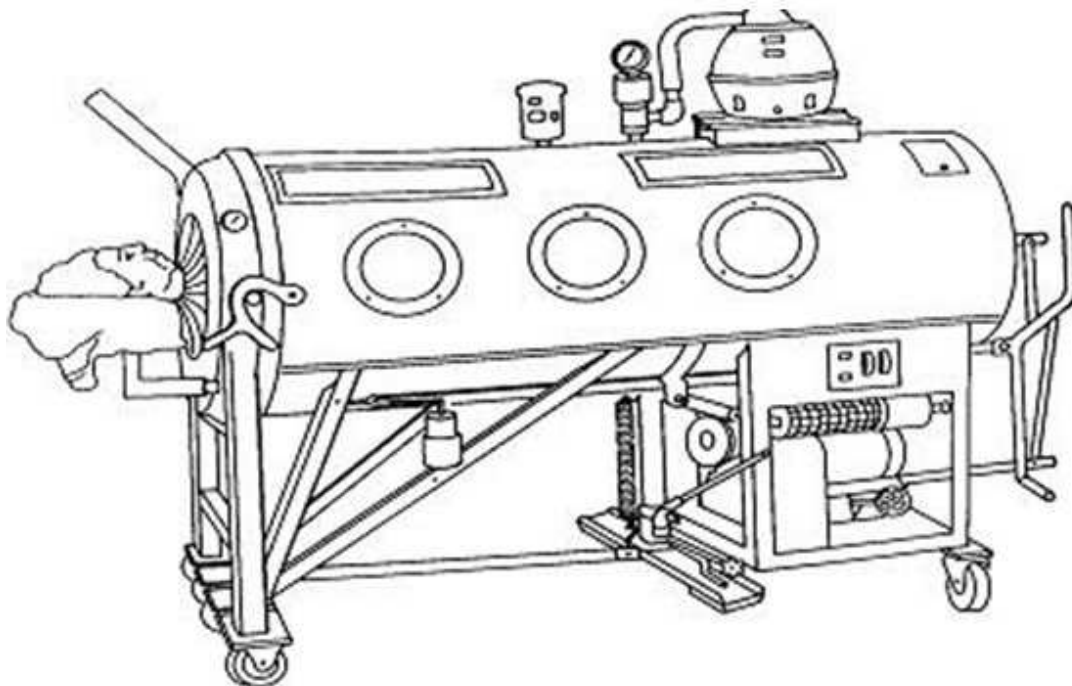

Figure 1: The bellows used to blow air in order to start a fire. Saleh Ibn Bouhlah and Royal Human Society used similar bellows and Royal Society for resuscitation of drowned persons (Al Jasser 1987)

So did the Society of resuscitation of drowned person 1769, and the Royal Human Society 1776 in efforts to resuscitating the drowned apparently dead. Automatic artificial ventilation of the lungs during chest surgery was known since 1896. Tuffier and Hallian in France successfully intubated and ventilated the lungs by using non-rebreathing valve. Chevalier Jackson in America popularized laryngoscopy and intubation in the first quarter of the 20th century. Cecil Drinker and his brother Philip developed a positive and negative pressure generating tank respirator and was used successfully on a child in Boston children hospital ². In 1948, muscle relaxants were introduced to anesthesia practice and anesthesiologists used to assist the intubated, partially paralyzed patient who had respiratory depression gained a great experience. In 1952, the polio epidemic in Copenhagen left many patient paralyzed and medical students were allocated to ventilate these patients continuously by hand (due to shortages of tank ventilators). They were using a self inflating bag and one way valve on an intubated patient. Bjorn Ibsen established the first intensive care unit in Copenhagen in 1953. The chronic patients who survived this epidemic were ventilated in negative pressure chamber "Iron Lungs" till their natural death [**Figure. 2 a., b.**].



Figure 2: The iron lung the apparatus used to produce artificial ventilation by producing a negative pressure around the chest and abdomen while the face is exposed to the atmosphere, which helped to draw air to the lungs. Obviously it was difficult to nurse the patients, but nevertheless some patient spends their life within it and they were able to speak, eat and even watch television. {Atkinson history of anesthesia symposium London 1987}(2a, 2b)



In the sixties of the 20th century, another development happened when physicians realized that the early preventable death from myocardial infarction was due to the occurrence of arrhythmias ^{3,4,5,6,7,8,9,10}. These hearts may survive the initial hyper-excitability stage if the arrhythmia was monitored and treated in time. The purpose of monitoring of myocardial infarction patients during the first 24, 48, &72 hours after the infarct is aimed at looking for these developments. [**Figure 3 a, b**].

Appreciation of the value of the intensive care setting made it imperative to extend its use to other class of patients and today we can count more than 20 subspecialties.



Figure 3: Various pictures, of modern intensive care unit, showing: (3a) the nursing station at KKUH, (3b) An intubated patient is ventilated, using modern intermittent positive pressure ventilation method.



Description Of An Intensive Care Unit

These units are special units where the effort is concentrated in one locality in the hospital and where the care of patients who are deemed

recoverable but who need supervision and need or likely to need specialized techniques by skilled personnel. Among this specialized technique we can enumerate continuous artificial ventilation, supporting the circulation, management of chock and renal dialysis. The utilization of this unit in the management of critical ill patient improved the outcome by reduction in expected mortality up to 60%. The Units have the following major characteristics: (1) space, equipment and working staff and (2) continuous service and care all around the clock 24 hours ¹¹ including all the following: instantaneous monitoring of cardiovascular parameter, respiratory function, renal function and the nervous system status. These settings are not seen in any other place in the hospital. The patient's categories that can benefit from this unit are

Patients of myocardial infarction who usually need continuous cardiovascular monitoring. Patients who needs artificial ventilation, cardiovascular support and renal support. Patients with major metabolic disturbances like patient with uncontrolled diabetes mellitus or patient after major abdominal surgeries. Patients with major trauma like patients with head injuries, chest injuries and other multiple injuries. Disaster medicine victims who are affected by multiple injuries.

Space and layout

There is tendency that the space per bed to be nears 20 m² and similar space for services totaling 40 m². As for cubicles the space should be 30 m². There should be adequate light natural white or pink white. There should be central air conditioning and warming¹¹. There also feasibility to have some entertainment as soft music or television.

Equipment

In the unit a provision of central medical gases supplies like oxygen and Entonox, vacuum for suction instruments. Electrical outlets are needed to facilitate the use of electrical apparatus. Washbasin and monitoring trays are also needed.

Monitoring

Monitoring permits to:

To monitor the heart electrical activities and other related output. To measure various blood pressures from arterial or venous side. In certain situation the calculation of cardiac output and to measure other cardiac indices are performed to guide patient's management.

Ventilation

Beside each bed a separate ventilator capable of working continuously and exclusively on one patient till his recovery and capable of generating all types of mode of ventilation the patient may need during his acute illness.

Staffing

Technical staff is needed. It is composed of two head nurses working in shifts. Medical residents on call should be provided. Consultants are in charge of the ICU to manage and organize consultation between other subspecialties in the hospital and do the patient rounds in the morning and evening. There should be one nurse per bed covering 24 hours shift and there should be a team of respiratory therapists and physiotherapist. There are also needs for laboratory assistant, porters, and other manual workers ^{12,13,14,15,16}.

Patient management

The patient on intensive care (like any other patient under treatment) has the right to considerate and respectful care. This is guaranteed by most guidelines and consensus opinion in most intensive care professional societies:

The patient should obtain complete current information concerning his/her diagnosis, treatment and prognosis in clear terms. Also to receive information necessary to give informed consent prior to the start of any procedure and/or treatment. The patient may refuse treatment as far as permitted by law, and to be informed of the medical consequences of his/her action. The patient is entitled to complete privacy concerning his/her own medical care program, and that all communications and records pertaining to his/her care should be treated as confidential.

The hospital makes reasonable responses to the requests of a patient, to

obtain information about relationship of his/her hospital to other health care and educational institutions insofar as his/her care is concerned and patients should be advised if the hospital proposes to engage in or perform human experimentation affecting his/her care or treatment,

The patient deserves reasonable continuity of care, and explanation of his/her bill and hospital rules and regulations applied to his/her conduct as a patient.

Costs

No doubt the life of a patient does not follow consideration of money. To regain one life from illness is a very rewarding experience. But the intensive care medicine is demanding because of the use of the sophisticated instruments, disposable items to prevent cross infection and to reduce the rate of infection. Also there is the consideration of utilizing the expertise of highly competent individuals with high salaries in order to keep them on the staff; all made the cost per bed an expensive cost. The statistics differ from country to countries and the minimal requirement of the intensive care, which are accepted. So the cost may range from SR 1000 - 20000 per bed per day.

Ethical Issues

Cross infections

The compromised patient with his health at its low is subjected to extra risk of infection, which can be transmitted from his caregiver or his visitors. So high level of care is needed and self-hygiene should be at highest ebb. There should be monitoring of the infection pattern and the bacteria monitored in order to take the necessary steps to treat infection, prevent resistance development and preventing hospital acquired cross infection.

Brain death

In spite of the development of high techniques in resuscitation there are some situation where the initial insult may have done its full impact on the patient who will be subjected for resuscitation and the rescuer will be

successful in regaining his vital function. It is necessary to see if a patient already has lost the function of the brain. The heart is still beating automatically and by the effect of supportive measure of the intensive care doctor. Artificial means sustain the ventilation. The cost of such situation is high materially and emotionally while the patient is a dead person according to the modern criteria of death. The relatives are seeing the body of their dear patient ventilated and motionless but the screen showing the traces of his heart beating and other parameters generated by his circulation. This will lead to false hope and expectations. The law allows testing for absent brain functions and certification by two consultants allow a death certificate to be issued. The idea of testing is to insure that the brain death is set in and there is irreversible brain damage.

Do not resuscitate situation

There are situation of chronic illnesses and terminal conditions which by the help of the intensive care setting would allow the management of one organ failure to be treated while the terminal condition is progressing. There are many views regarding the feasibility to treat or not to treat these patients regarding the preservation of the human dignity and not to treat the patient organ by organ without putting into consideration the quality of life. Modern hospitals do have committees who can look into individual case and take a decision in an objective way to support or decline such decision of do not resuscitate order.

Vegetative neurological states

Still there are conditions, which occur due to trauma or severity of the disease where the state of cerebral function is not preserved and much affected. These patients do not fall under the brain dead criteria but are termed vegetative state patients. These patients constitute a difficult situation and decision-making dilemma. Would the intensive care team carry on giving the tender-loving care on very costly basis? Would they be candidates for intensive care management? Again, these patients pose family and social suffering and the courts in many countries were involved to rule one way or another in their cases.

References

1. Jasser M.T Anaesthesia in the history of Islamic Medicine, in The History of anaesthesia. International congress and symposium series 134 (eds.) Atkinson R.S., and Boulton T.B. Royal Society of Medicine Services and The Parthenon Publishing Group, London - New York 1989 (s)
2. Thirlwell J. Cover note. *Anaesth Intens Care*. 1986, 14, 236-250 (s)
3. Zoll P.M., Linenthal A.J., Gibson W., Pall M.H., Normal L.R. Termination of ventricular fibrillation in man by externally applied electric countershock. *N Engl J Med*. 1956; 254:727-732. (s)
4. Safer P., Escarraga L.A., Elam J.O. A comparison of the mouth-to-mouth and mouth-to-airway methods of artificial respiration, with the chest pressure arm lift methods. *N Engl J Med*. 1958; 258:671-677. (s)
5. Kouwenhoven WB, Jude JR, Knickerbocker GG. Landmark article July 9, 1960: Closed-chest cardiac massage. By W. B. Kouwenhoven, James R. Jude, and G. Guy Knickerbocker. *JAMA*. 1984;15;251(23):3133-6. (s)
6. Kouwenhoven WB, Langworthy OR . Cardiopulmonary resuscitation. An account of forty-five years of research. *Johns Hopkins Med J*. 1973; 132(3):186-93. (s)
7. Wilder RJ, Jude JR, Kouwenhoven WB, Mc Mahon MC. Of 153 Attempted-Cardiopulmonary resuscitations by trained ambulance personnel-No fatal injuries were produced. *JAMA*. 1964,9: 190:531-4. (s)
8. Jude JR, Kouwenhoven WB, Knickerbocker GG. Cardiac arrest. Report of application of external cardiac massage on 118 patients. *JAMA*. 1961; 16;178:1063-70 (s)
9. Jude JR, Kouwenhoven WB, Knickerbocker GG. A new approach to cardiac resuscitation. *Ann Surg*. 1961; 154:311-9. (s)
10. The American Heart Association in collaboration with International Liaison Committee on Resuscitation (ILCOR). The international Consensus on Science. Guidelines 2000 for Cardiopulmonary resuscitation and emergency cardiovascular care. *Circulation*, 2000;102(suppl 1):11.1-1.12-1.22 (s)

11. British Medical Association (1967) Intensive care BMA Planning UNIT Report No1 London. British Medical Association. ([s](#))
 12. Hilberman M. The evaluation of intensive care units. Crit. Care. Med. 1975;3,159-165 ([s](#))
 13. Intensive Care Society. Standards for intensive care units. : Intensive Care Society. London 1997. ([s](#))
 14. Intensive Care Society. Levels of care for adult patients. : Intensive Care Society. London. 2002a. ([s](#))
 15. Intensive Care Society. Guidelines for the provision of outreach services. Intensive Care Society. London: 2002b. ([s](#))
 16. Galley J., O' Riordan B. Guidance for nurse staffing in critical care. Royal college of nursing () London W1G 0RN. 2003. RCNONLINE <http://www.RCN.org.uk> ([s](#))
-

This article was last modified on Fri, 13 Feb 09 13:34:12 -0600

This page was generated on Tue, 06 Apr 10 03:11:59 -0500, and may be cached.