

555 TIMER

Introduction

The **555 timer** is an **integrated circuit** (chip) implementing a variety of timer and **multivibrator** applications. It was produced by Signetics Corporation in early 1970. The original name was the SE555/NE555 and was called "The IC Time Machine". The 555 gets its name from the three 5-K Ω resistors used in typical early implementations. It is widely used because of its ease to use, low price and reliability.

It is one of the most popular and versatile integrated circuits which can be used to build lots of different circuits. It includes 23 transistors, 2 diodes and 16 resistors on a silicon chip installed in an 8-pin mini dual-in-line package (DIP-8)(Refer to Figure 1).

The 555 Timer is a **monolithic** timing circuit that can produce accurate and highly stable time delays or oscillations. The timer basically operates in one of the two modes—**monostable (one-shot)** multivibrator or as an **astable** (free-running) multivibrator. In the monostable mode, it can produce accurate time delays from microseconds to hours. In the astable mode, it can produce rectangular waves with a variable **duty cycle**. Frequently, the 555 is used in astable mode to generate a continuous series of pulses, but you can also use the 555 to make a one-shot or monostable circuit.

The 555 can source or sink 200 mA of output current, and is capable of driving wide range of output devices. The output can drive **TTL (Transistor-Transistor Logic)** and has a temperature stability of 50 parts per million (ppm) per degree Celsius change in temperature, or equivalently 0.005 %/°C.

Applications of 555 timer in monostable mode include timers, missing pulse detection, bounce free switches, touch switches, frequency divider, capacitance measurement, pulse width modulation (PWM) etc.

In astable or free running mode, the 555 can operate as an oscillator. The uses include LED and lamp flashers, logic clocks, security alarms, pulse generation, tone generation, pulse position modulation, etc. In the bistable mode, the 555 can operate as a flip-flop and is used to make bounce-free latched switches, etc.

Refer to Figure 1 for the brief description of the pin connections. The pin numbers used refer to the 8-pin mini DIP and 8-pin metal can packages. The 555 can be used with a supply voltage (V_{CC}) in the range 4.5 to 15V (18V absolute maximum).

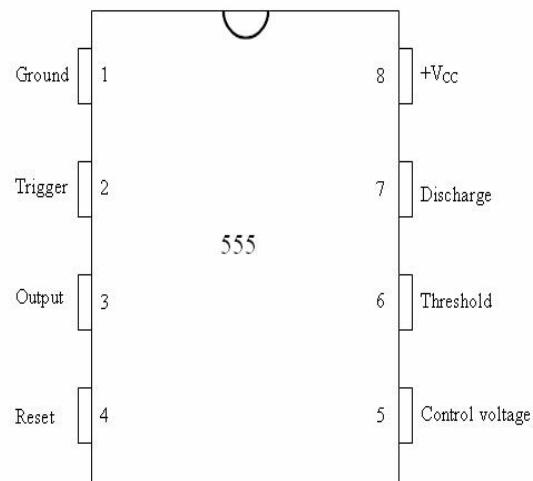

Figure 1: Pin out diagram of 555 Timer

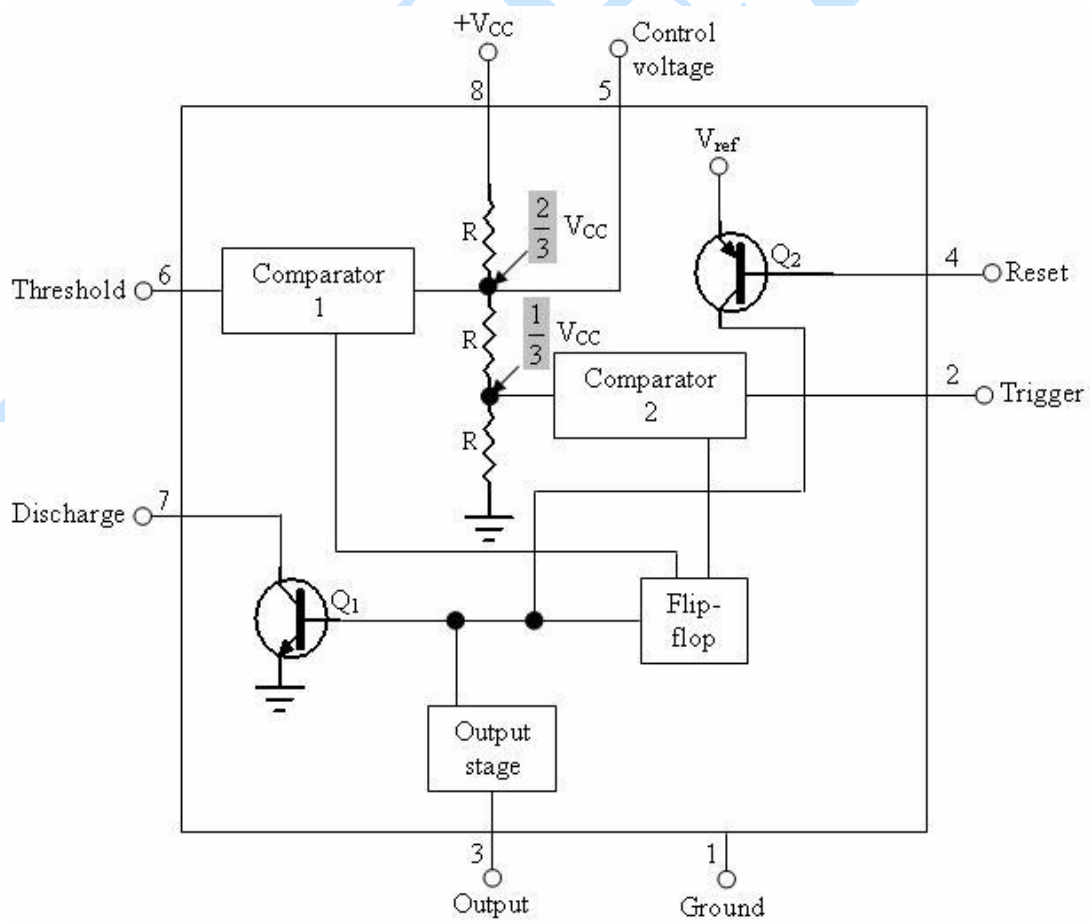

Figure 2: Functional Block Diagram of 555 Timer

The pin connections of the 555 timer are as follows:

Pin 1: Ground: All voltages are measured with respect to this terminal.

Pin 2: **Trigger**: The external trigger pulse is applied to this pin. The output of the timer is low if the voltage at this pin is greater than $\frac{2}{3}V_{CC}$. If a negative going pulse of amplitude larger than $\frac{1}{3}V_{CC}$ is applied to this pin, the output of **comparator 2** becomes low, which in turn makes the output of the timer high. The output remains high as long as the trigger terminal remains at low voltage.

Pin 3: Output: There are two ways a load can be connected to the output terminal — either between pin 3 and ground (pin 1) or between pin 3 and the supply voltage $+V_{CC}$ (pin 8). When the output is low, the load current flows through the load connected between pin 3 and pin 8 into the output terminal and is called the sink current. However, the current through the grounded load is zero. Therefore, the load between pin 3 and $+V_{CC}$ is called “normally on load” and that connected between pin 3 and ground is called “normally off load”. On the other hand, when the output is high, the current through the load connected between pin 3 and $+V_{CC}$ (“normally on load”) is zero. However, the output terminal supplies current to the “normally off load”. This current is called the source current. The maximum value of sink or source current is 200 mA.

Pin 4: Reset: The 555 timer can be reset or disabled by applying a negative pulse to this pin. When not in use, the reset terminal is connected to $+V_{CC}$ to avoid the possibility of false triggering.

Pin 5: **Control Voltage**: An external voltage may be applied to this terminal to change the threshold as well as the trigger voltage. The pulse width of the output waveform is hence dependent on it. When not in use, the control pin should be bypassed to ground with a 0.01 μF capacitor (refer to Figures 4, 6 and 7) to prevent any noise problems.

Pin 6: Threshold: This is the non-inverting input terminal of the comparator 1. When the voltage at this pin becomes greater than or equal to the **threshold voltage** $\frac{2}{3}V_{CC}$, the output of this comparator becomes high, which in turn, switches the output of the timer low.

Pin 7: Discharge: This pin is connected internally to the collector of a **transistor** Q_1 . When the output of the timer is high, Q_1 is off and acts as an open circuit to an external

capacitor C connected across it (refer to Figure 7). On the other hand, when the output of the timer is low, Q_1 is saturated and acts as a short circuit, shorting C to ground.

Pin 8: $+V_{CC}$: The supply voltage of +5 V to + 18 V is applied to this pin with respect to ground (pin 1).

We now discuss the working of 555 timer using its functional block diagram (Refer to Figure 2).

As shown in Figure 2, the 555 timer consists of a voltage divider arrangement, two comparators, an **RS flip-flop**, an n-p-n transistor Q_1 and a p-n-p transistor Q_2 . Since the voltage divider has equal resistors, the upper comparator has a **trip point** of

$$UTP = \frac{2}{3}V_{CC}$$

The comparator 2 has a trip point of

$$LTP = \frac{1}{3}V_{CC}.$$

As seen in the Figure 2, the pin 6 (Threshold) is connected to the comparator 1. This voltage comes from the external components (not shown). When the threshold is greater than the UTP, the comparator 2 has a high output. Pin 2 (trigger) is connected to the comparator 2. This is the trigger voltage that is used for the monostable operation of the 555 timer. When the trigger is inactive, the trigger voltage is high. When the trigger voltage falls to less than the LTP, comparator 2 produces a high output.

In order to understand how a 555 timer works with external components, we need to discuss the action of RS flip-flop, the block that contains S, R, Q and \bar{Q} (Figure 3).

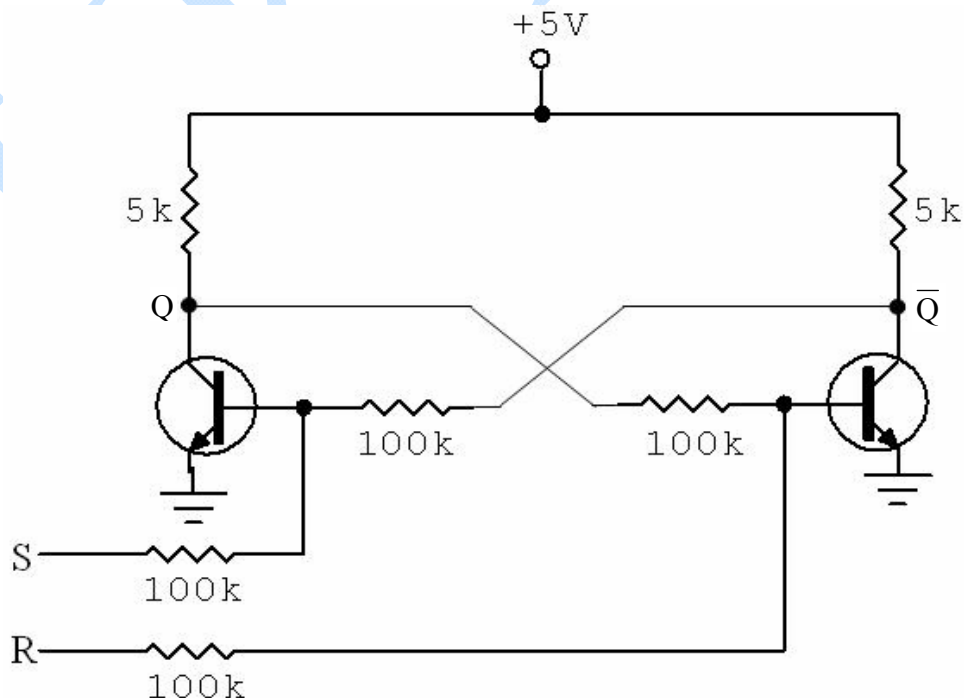

Figure 3: RS Flip-Flop

Figure 3 shows one way to build an RS flip-flop. In a circuit like this, one of the transistors is saturated, and the other is cut off. For instance, if the right transistor is saturated, its collector voltage will be approximately zero. This means that there is no base current in the left transistor. As a result, the left transistor is cut off, producing high collector voltage. This high collector voltage produces a large base current that keeps the right transistor in saturation.

The RS flip-flop has two outputs, Q and \bar{Q} (the output of the left and the right transistor respectively). These are two state outputs, either low or high voltages. Further, the two outputs are always in opposite states. When Q is low, \bar{Q} is high. When Q is high, \bar{Q} is low. For this reason \bar{Q} is called the complement of Q .

The output states can be controlled with the S and R inputs. If we apply a large positive voltage to the S input, we can drive the left transistor into saturation. This will cut off the right transistor. In this case, Q will be high and \bar{Q} will be low. The high S input can then be removed because the saturated left transistor will keep the right transistor in cutoff.

Similarly, we can apply a large positive voltage to the R input. This will saturate the right transistor and cutoff the left transistor. For this condition, Q is low and \bar{Q} is high. After this transition has occurred, the high R input can be removed because it is no longer needed.

Since the circuit is stable in either of two states, it is sometimes called a **bistable** multivibrator. A bistable multivibrator latches in either of two states. A high S input forces Q into the high state, and a high R input forces Q to return to the low state. The output Q remains in a given state until it is triggered into the opposite state. The S input is sometimes called the set input because it sets the Q output to high. The R input is called the reset input because it resets the Q output to low.

Learning Outcomes

After performing this experiment, you will be able to

1. state various applications of 555 timer
2. describe the pin functions of 555 timer
3. discuss the role of an RS flip-flop in the working of 555 timer
4. explain the basic functioning of 555 timer
5. design an astable multivibrator of given frequency and duty cycle
6. design a monostable multivibrator of given pulse-width.

SECTION A

ASTABLE MULTIVIBRATOR

We now take up the application of 555 timer as an astable multivibrator. An astable multivibrator is a wave-generating circuit in which neither of the output levels is stable. The output keeps on switching between the two unstable states and is a periodic, rectangular waveform. The circuit is therefore known as an 'astable multivibrator'. Also, no external trigger is required to change the state of the output, hence it is also called 'free-running multivibrator'. The time for which the output remains in one particular state is determined by the two resistors and a capacitor externally connected to the 555 timer.

APPARATUS

- CRO (cathode ray oscilloscope)
- power supply (+5V to +18V)
- 555 timer
- resistors
- capacitors
- connecting wires
- connecting leads of CRO
- bread board

THEORY

Figure 4 shows 555 timer connected as an astable multivibrator. Pin 5 is bypassed to ground through a 0.01 μF capacitor. The power supply ($+V_{CC}$) is connected to common of pin 4 and pin 8 and pin 1 is grounded. If the output is high initially, capacitor C starts charging towards V_{CC} through R_A and R_B . As soon as the voltage across the capacitor becomes equal to $\frac{2}{3}V_{CC}$, the upper comparator triggers the flip-flop, and the output becomes low. The capacitor now starts discharging through R_B and transistor Q_1 . When the voltage across the capacitor becomes $\frac{1}{3}V_{CC}$, the output of the lower comparator triggers the flip-flop, and the output becomes high. The cycle then repeats. The output voltage and capacitor voltage waveforms are shown in Figure 5.

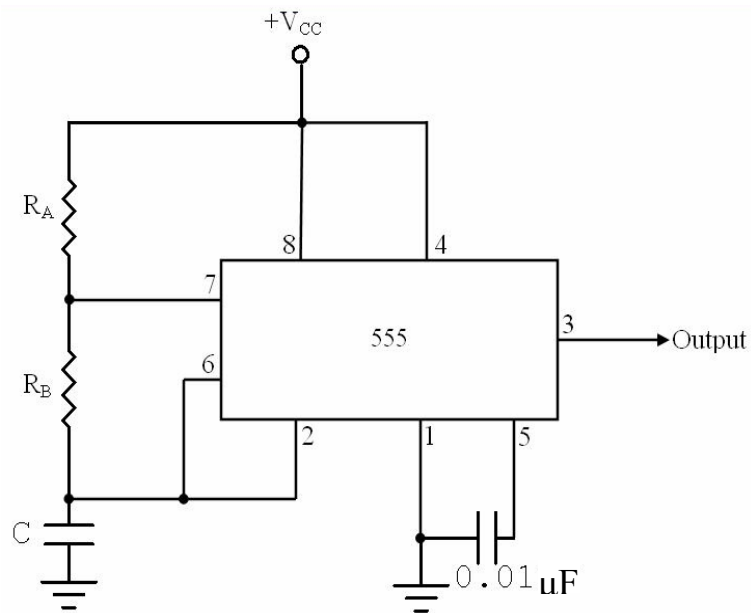

Figure 4: Circuit diagram for Astable Multivibrator

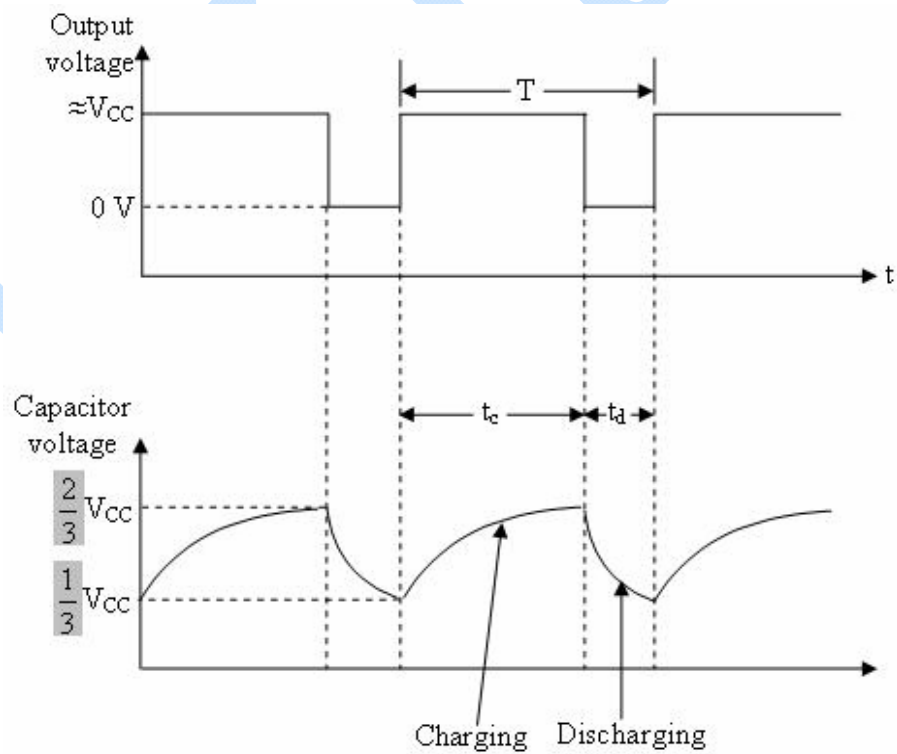

Figure 5: Output voltage waveforms

As can be seen from the Figure 5, the capacitor voltage waveform is an exponentially rising and falling waveform between $\frac{2}{3}V_{CC}$ and $\frac{1}{3}V_{CC}$ which represents periodic charging and discharging of the capacitor between $\frac{2}{3}V_{CC}$ and $\frac{1}{3}V_{CC}$. The time during which the capacitor charges from $\frac{1}{3}V_{CC}$ to $\frac{2}{3}V_{CC}$ is equal to the time the output is high and is given by

$$t_c = 0.69(R_A + R_B)C, \quad (1)$$

where R_A and R_B are in ohms and C in Farads. Similarly, the time during which the capacitor discharges from $\frac{2}{3}V_{CC}$ to $\frac{1}{3}V_{CC}$ is equal to the time the output is low and is given by

$$t_d = 0.69R_B C, \quad (2)$$

where R_B is in ohms and C in Farads. The total period of the output waveform is (using Equations (1) and (2))

$$T = t_c + t_d = 0.69(R_A + 2R_B)C \quad (3)$$

Thus the frequency of oscillation is

$$f_o = \frac{1}{T} = \frac{1.45}{(R_A + 2R_B)C} \quad (4)$$

The free-running frequency f_o is independent of the supply voltage V_{CC} .

The duty cycle is the ratio of the time t_c for which the output is high to the time period T . It is generally expressed as a percentage. The % duty cycle (using Equations (1) and (3))

$$\begin{aligned} D &= \frac{t_c}{T} \times 100 \\ &= \frac{R_A + R_B}{R_A + 2R_B} \times 100 \end{aligned} \quad (5)$$

According to the above relation, a duty cycle of less than 50% cannot be achieved. Also, 50% duty cycle, which corresponds to a square wave, can be achieved only if $R_A = 0$ resulting in terminal 7 being directly connected to V_{CC} . When the capacitor discharges through R_B and Q_1 , an extra current is supplied to Q_1 by V_{CC} through the terminal 7 (now directly connected to V_{CC}), which may damage Q_1 and hence the timer.

An alternative approach to achieve a duty cycle of less than or equal to 50% is to connect a diode D across resistor R_B as shown in Figure 6. In this case, the capacitor C charges through R_A and diode D to approximately $\frac{2}{3}V_{CC}$ and discharges through R_B and

transistor Q_1 until the capacitor voltage equals approximately $\frac{1}{3}V_{CC}$, after which the cycle repeats. The time for which the output is high is given by

$$t_c = 0.69R_A C, \quad (6)$$

and the time for which the output is low is given by

$$t_d = 0.69R_B C. \quad (7)$$

Thus the total period of the output waveform is

$$T = t_c + t_d = 0.69(R_A + R_B)C \quad (8)$$

and the frequency of oscillation is

$$f_o = \frac{1}{T} = \frac{1.45}{(R_A + R_B)C}. \quad (9)$$

The % duty cycle is (using Equations (6) and (8))

$$D = \frac{R_A}{R_A + R_B} \times 100. \quad (10)$$

If $R_A = R_B$, the duty cycle is 50%. For $R_A < R_B$, the duty cycle is less than 50%.

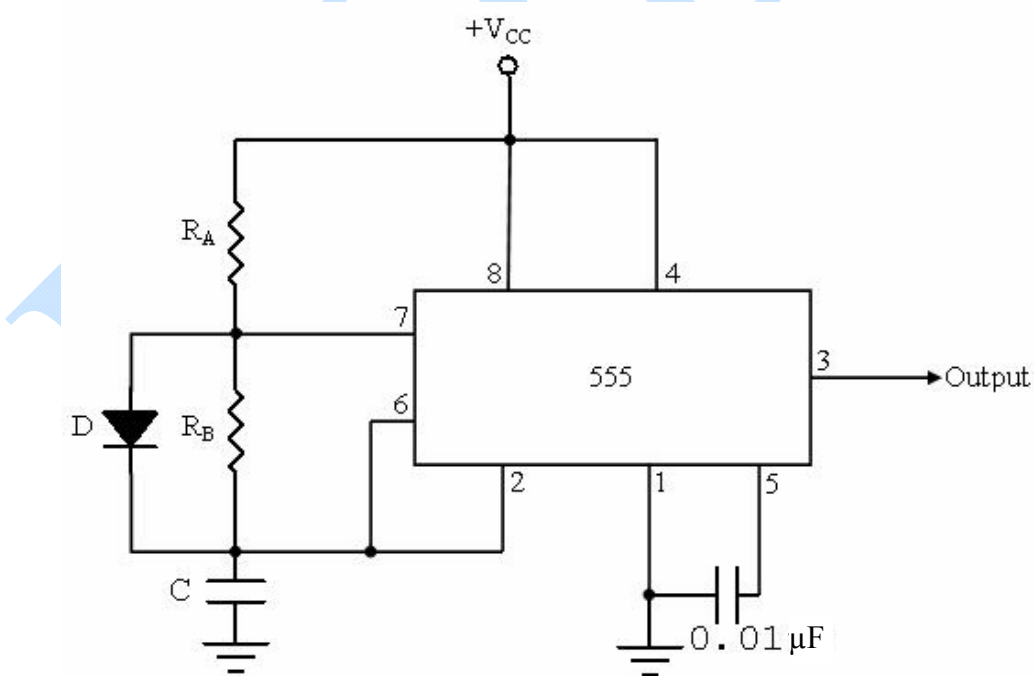

Figure 6: Circuit diagram for astable multivibrator with duty cycle $\leq 50\%$

Designing an astable multivibrator of given duty cycle and frequency

If we want to design an astable multivibrator of 75% duty cycle and 1 KHz frequency, from Equation (5), the duty cycle is

$$\frac{R_A + R_B}{R_A + 2R_B} = 0.75 \quad (11)$$

Solving, we have

$$R_A = 2R_B \quad (12)$$

Using this in Equation (4), the free-running frequency is given by

$$f_o = \frac{1.45}{4R_B C} \quad (13)$$

Substituting $C = 0.1 \mu\text{F}$ and $f_o = 1 \text{ KHz}$ in Equation (13), we get

$$R_B = \frac{1.45}{4 \times 1000 \times 0.1 \times 10^{-6}} = 3.6 \text{ K}\Omega \quad (14)$$

and from Equation (12),

$$R_A = 7.2 \text{ K}\Omega \quad (15)$$

Similarly, for a duty cycle of 50% and 1 KHz frequency $R_A = R_B = 7.25 \text{ K}\Omega$ and $C = 0.1 \mu\text{F}$.

For a duty cycle of 30% and 1 KHz frequency $R_A = 0.87 \text{ K}\Omega$, $R_B = 2.03 \text{ K}\Omega$ and $C = 0.5 \mu\text{F}$.

Pre-lab Assessment

Choose the correct answer

- (1) The applications of 555 timer include
 - a) monostable and astable multivibrators
 - b) waveform generators
 - c) voltage regulators
 - d) all of the above.
- (2) Which of the following is true of the 555 timer?
 - a) It is a monolithic timing circuit which can operate in monostable as well as astable mode.
 - b) It can source or sink 400mA.
 - c) Both (a) and (b)
 - d) None of the above
- (3) The functional block diagram of a 555 timer consists of
 - a) two comparators
 - b) two transistors and a voltage divider arrangement
 - c) a, b and an RS flip-flop

- d) a and b.
- (4) An RS flip flop is the same as a/an
- monostable multivibrator
 - one-shot multivibrator
 - bistable multivibrator
 - astable multivibrator.
- (5) A quasi-stable state is such that the output
- does not change at all
 - changes unpredictably
 - changes after a predetermined period of time
 - changes just after a very short duration of time.
- (6) A free-running multivibrator has
- one stable and one quasi-stable state
 - two stable states
 - two quasi-stable states
 - none of the above.
- (7) The output of an astable multivibrator
- remains high as long as the capacitor is charging
 - remains high as long as the capacitor is discharging
 - remains low as long as the capacitor is charging
 - has no relation with charging or discharging of capacitor.
- (8) The Duty cycle of a square wave is
- zero
 - less than 50%
 - 50%
 - greater than 50%.
- (9) Pin 5 is bypassed to ground through a $0.01 \mu\text{F}$ capacitor to prevent problems due to random electrical noise. (True / False)
- (10) The upper comparator in the functional block diagram of 555 timer has a trip point of $\text{UTP} = \frac{1}{3}V_{CC}$ and the lower comparator has a trip point of $\text{LTP} = \frac{2}{3}V_{CC}$. (True / False)

Procedure

- Connect the circuit as shown in Figure 4 with the calculated values of R_A , R_B and C for 75% duty cycle.
- The CRO is connected between pin 3 and pin 1 to see the (rectangular) output waveform.
- Measure the charging time t_c and discharging time t_d for a suitable value of time/div selected on CRO. Enter the data in Table 1.
- Select a different value of time/div on the CRO and repeat steps 1 to 3.
- Now, connect the other channel of the CRO between pin 6 and pin 1 to obtain the voltage across the capacitor.

	(cm)	(sec / cm)	t_c (sec)	(cm)	(sec / cm)	t_d (sec)			
1									
2									

Mean duty cycle = %.

Result

An astable multivibrator of given duty cycle and frequency is designed. A comparison of the experimental values with the given ones is represented below:

Quantity measured	Theoretical value	Experimental value
Frequency		
Duty cycle		

Post-lab Assessment

Choose the correct answer

- (1) For changing the output state of an astable multivibrator
 - a) no external trigger input is required
 - b) a positive pulse input is required
 - c) a negative pulse input is required
 - d) a high input is required.
- (2) To get an astable output whose Duty Cycle is slightly greater than 50%, R_A should be
 - a) much smaller than R_B
 - b) much larger than R_B
 - c) equal to R_B
 - d) smaller than R_B .
- (3) Can a 555 timer connected in an astable mode be used to generate rectangular waves with Duty Cycle less than or equal to 50%?
 - a) Yes, by using a diode and choosing particular values for external components R_A , R_B and C.
 - b) Yes, only by choosing particular values for external components R_A , R_B and C.
 - c) No, it has to be connected in monostable mode.
 - d) Not possible.
- (4) The frequency of oscillation for a 555 timer connected in astable mode, with $R_A = R_B = 1K\Omega$ and $C = 1000\text{ pF}$, is
 - a) 725 KHz

- b) 483 KHz
 - c) 966 KHz
 - d) none of the above.
- (5) The Duty Cycle of the waveform generated by an astable multivibrator is approximately 67% if
- a) $R_A = R_B = 1k\Omega$
 - b) $R_A = R_B = 2k\Omega$
 - c) $R_A = R_B = 3k\Omega$
 - d) (a), (b) or (c).
- (6) The Duty Cycle of the rectangular waveform produced by 555 timer connected in astable mode
- a) increases with increase in the value of capacitance
 - b) decreases with increase in the value of capacitance
 - c) decreases with decrease in the value of capacitance
 - d) is independent of the value of capacitance.
- (7) An external trigger is required to change the state of the output of an astable multivibrator. (True/False)
- (8) When a 555 timer is connected in astable mode, the time for which the output remains in one particular state is determined only by the two resistors externally connected to the 555 timer. (True/False)
- (9) Does the free-running frequency f_o of an astable multivibrator depend on the supply voltage V_{CC} ? (Yes / No)

Answer the following question

- (10) If a diode is connected across R_B in the astable multivibrator circuit, what is the condition on R_A and R_B to achieve a duty cycle of 50%?

Answers to Pre-lab Assessment

- 1. d
- 2. a
- 3. c
- 4. c
- 5. c
- 6. c
- 7. a
- 8. c
- 9. True
- 10. False

Answers to Post lab assessment

1. a
2. a
3. a
4. b
5. d
6. d
7. False
8. False
9. No
10. $R_A = R_B$

UNIVERSITY

SECTION B

MONOSTABLE MULTIVIBRATOR

We now discuss another important application of 555 timer, that is, 555 timer as a monostable multivibrator. A monostable multivibrator is a pulse-generating circuit having one stable and one quasi-stable state. Since there is only one stable state, the circuit is known as 'monostable multivibrator'. The duration of the output pulse is determined by the RC network connected externally to the 555 timer. The stable state output is approximately zero or at logic-low level. An external trigger pulse forces the output to become high or approximately V_{CC} . After a predetermined length of time, the output automatically switches back to the stable state and remains low until a trigger pulse is again applied. The cycle then repeats. That is, each time a trigger pulse is applied, the circuit produces a single pulse. Hence, it is also called 'one-shot multivibrator'.

Apparatus

- CRO (cathode ray oscilloscope)
- power supply (+5V to +18V)
- 555 timer
- resistors
- capacitors
- connecting wires
- connecting leads for CRO
- bread board

Theory

A 555 timer connected for monostable operation is shown in Figure 7. The circuit has an external resistor and capacitor. The voltage across the capacitor is used for the threshold to pin 6. When the trigger arrives at pin 2, the circuit produces output pulse at pin 3.

Initially, if the output of the timer is low, that is, the circuit is in a stable state, transistor Q_1 is on and the external capacitor C is shorted to ground. Upon application of a negative trigger pulse to pin 2, transistor Q_1 is turned off, which releases the short circuit across the capacitor and as a result, the output becomes high. The capacitor now starts charging

up towards V_{CC} through R_A . When the voltage across the capacitor equals $\frac{2}{3}V_{CC}$, the output of comparator 1 switches from low to high, which in turn makes the output low via the output of the flip-flop. Also, the output of the flip-flop turns transistor Q_1 on and hence the capacitor rapidly discharges through the transistor. The output of the monostable multivibrator remains low until a trigger pulse is again applied. The cycle then repeats. Figure 8 shows the trigger input, output voltage, and capacitor voltage waveforms. As shown, the pulse width of the trigger input must be smaller than the expected pulse width of the output waveform. Moreover, the trigger pulse must be a negative-going input signal with an amplitude larger than $\frac{1}{3}V_{CC}$. The time for which the output remains high is given by

$$t_p = 1.1 R_A C, \quad (16)$$

where R_A is in ohms, C in farads and t_p in seconds. Once the circuit is triggered, the output will remain high for the time interval t_p . It will not change even if an input trigger is applied during this time interval. In other words, the circuit is said to be non-retriggerable. However, the timing can be interrupted by the application of a negative signal at the reset input on pin 4. A voltage level going from $+V_{CC}$ to ground at the reset input will cause the timer to immediately switch back to its stable state with the output low.

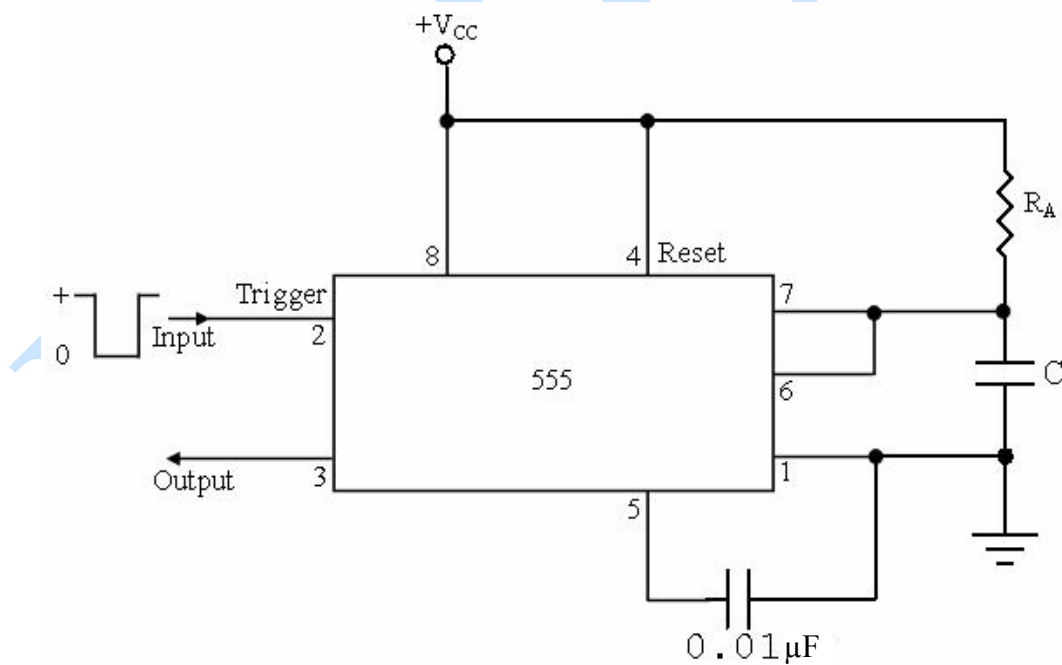

Figure 7: Monostable multivibrator
The trigger input

ut may be driven by the output of astable multivibrator with high duty cycle. If the desired pulse width is of the order of seconds, the output can be seen using a LED and the resistance value used will be of the order of $M\Omega$. In this case the trigger can be supplied manually by grounding the trigger input for a fraction of a second.

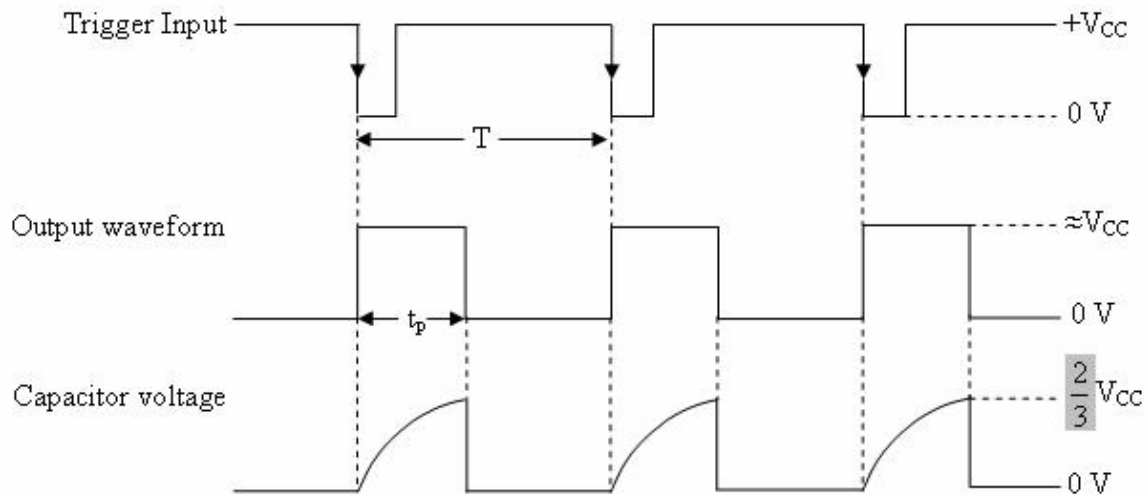

Figure 8: Input and output voltage waveforms

Designing a monostable multivibrator

If we want to design a monostable multivibrator for a pulse-width of 1 ms for a given $C = 0.5 \mu F$, then using Equation (16), we get R_A to be 1.82 K Ω .

Pre-lab Assessment

Choose the correct answer

- (1) The output waveform of a 555 timer is always
 - a) sinusoidal
 - b) triangular
 - c) rectangular
 - d) square.
- (2) A multivibrator circuit having one stable state and other quasi-stable state is known as
 - a) monostable multivibrator
 - b) bistable multivibrator
 - c) astable multivibrator
 - d) free-running multivibrator.
- (3) A monostable multivibrator is also called a 'one-shot multivibrator' because
 - a) each time a trigger pulse is applied, the circuit produces a single pulse.
 - b) the circuit has to be triggered only once
 - c) the output pulse duration is very small
 - d) none of the above.

- (4) The output of a monostable multivibrator remains high
- while the external capacitor is charging
 - while the external capacitor is discharging
 - while the trigger is held high
 - a and c
- (5) The output of a monostable multivibrator remains low
- while the external capacitor is charging
 - while the external capacitor is discharging
 - while the trigger is held high
 - a and c
- (6) When a 555 timer is connected in monostable mode, the voltage across the external capacitor is used for the threshold to pin 6. (True/False)
- (7) Once the circuit is triggered and the output becomes high, it remains so for the time interval t_p and will not change even if an input trigger is applied during this time interval. (True / False)
- (8) Is it possible to achieve a stable state output within the time interval t_p using a reset terminal? (Yes / No)

Procedure

- Connect the circuit as shown in Figure 7 with the calculated values of R and C .
- The oscilloscope is connected between pin 3 and pin 1 to see the (rectangular pulse) output waveform.
- Measure the pulse width t_p for a suitable value of time/div selected on CRO. Enter the data in Table 4.
- Select a different value of time/div on the CRO and repeat steps 1 to 3.
- Now, connect the other channel of the CRO between pin 6 and pin 1 to obtain the voltage across the capacitor.
- Trace the output voltage waveform and the voltage across the capacitor.
- Take the mean for calculated values of pulse width.

Observations

Table 4: $C = 0.5\mu\text{F}$, $R_A = 1.82 \text{ K}\Omega$

S. No.	Pulse width t_p (ms)		
	Trace length (cm)	Time / div (sec / cm)	Pulse width t_p (ms)
1			
2			

Mean pulse width = ms.

Result

A monostable multivibrator of given pulse width is designed. A comparison of the experimental pulse width with the given one is mentioned below:

Quantity measured	Theoretical value	Experimental value
Pulse width		

Glossary

555 timer: It is a monolithic timing circuit that basically operates in monostable (one-shot) or astable (free-running) mode. It can also work as a bistable multivibrator which is the same as an RS flip-flop. 555 timer is called so because three 5 K Ω resistors were used in the voltage divider arrangement within the integrated circuit earlier.

Astable: A mode in which a 555 timer has no stable state and produces a rectangular wave of predetermined frequency.

Bistable: A mode in which 555 timer has two stable output states and the output is latched in either of the two states.

Comparator: It is an application of op-amp and is described as a circuit that compares two analog voltages, an input voltage and a reference voltage also called the trip point. The output is either a low or a high voltage.

Control voltage: An external voltage which may be applied to change the threshold as well as the trigger voltage and hence also the pulse-width of the output waveform.

DIP: It is an acronym for Dual-Inline Package and refers to a type of integrated circuit packaging that has two rows of external connecting terminals.

Duty Cycle: It is the ratio of the time t_c for which the output of an astable multivibrator is high to the time period T of the output waveform. It is generally expressed as a percentage.

Integrated Circuit: A miniaturized electronic circuit consisting mainly of semiconductor devices, as well as passive components, that has been manufactured in the surface of a thin substrate of semiconductor material

Monolithic: The common form of chip design or an integrated circuit, in which the base material (semiconductor substrate) contains the pathways as well as the active elements that take part in its operation.

Monostable: A mode in which a 555 timer produces a rectangular output pulse of known pulse-width. It is also called one-shot.

Multivibrator: A two-state circuit with zero, one or two stable output states depending on whether it is connected in astable, monostable or bistable mode.

One-shot: Same as monostable.

RS flip-flop: The most fundamental latch or an electronic circuit with two stable output states, either high or low, always opposite to each other and controlled by the inputs R and S which stand for reset and set, respectively. It is basically a kind of bistable multivibrator.

Threshold voltage: The voltage given at the non-inverting input terminal of the op-amp used as the upper comparator in the block diagram of 555 timer.

Transistor: An active three-terminal semiconductor device that can be used either as an amplifier or as a switch. The two basic types are bipolar junction transistors (BJTs) and field effect transistors (FETs). A BJT can be either npn or pnp.

Transistor-Transistor Logic (TTL): A class of digital circuits built from bipolar junction transistors and resistors. It is named so because both the logic gating function and the amplifying function are performed by transistors.

Trigger: It basically means to initiate an action and refers to a sharp input pulse of voltage or current used to turn on a switching device.

Trip point: The value of the input reference voltage of a comparator is called trip point.

Post-lab Assessment

Choose the correct answer

- (1) The output state of a 555 timer connected in a monostable mode with a high trigger input is
 - a) low
 - b) high
 - c) either high or low
 - d) not stable.
- (2) The pulse-width of the wave generated by a monostable multivibrator with $R_A = 68 \text{ k}\Omega$ and $C = 0.1 \text{ }\mu\text{F}$ is
 - a) 3.74 ms
 - b) 7.48 ms
 - c) 7.48 μs
 - d) none of the above.
- (3) The pulse-width of the wave generated by a one-shot multivibrator decreases when the
 - a) supply voltage decreases
 - b) timing resistor increases
 - c) UTP increases
 - d) timing capacitance decreases.
- (4) For the proper functioning of a monostable multivibrator, what must be the relative magnitude of the pulse-width of the trigger input in comparison to the expected pulse-width of the output waveform?
 - a) It must be smaller
 - b) It must be larger
 - c) It must be the same
 - d) It can have any magnitude.

- (5) The trigger input may be
- driven by the output of astable multivibrator with high duty cycle.
 - supplied manually by grounding the trigger input for a fraction of a second.
 - both a and b
 - only a.
- (6) Once the output of the monostable multivibrator has switched to the stable low state, it remains low until a trigger pulse is again applied. (True / False)
- (7) For the proper functioning of a monostable multivibrator, the trigger pulse must be a negative-going input signal with an amplitude larger than $\frac{2}{3}V_{CC}$. (True/False)

Answer the following question

- (8) What is the time for which the output remains high?

Answers to Pre-lab Assessment

- c
- a
- a
- a
- c
- True
- True
- Yes

Answers to Post-lab Assessment

- a
- b
- d
- a
- c
- True
- False
- $t_p = 1.1 R_A C$

UKLEER